



Fast Track

# The ALARIS FULL HEIGHT



**ELEGANT DESIGN-DURABLE  
MECHANISM-FAST PASSAGE-SAFE  
AND SECURE- USER FRIENDLY**

The Alaris-Full Height gate offers an efficient and aesthetic option for access control with its stylish design as a combination of glass wings and stainless steel body.

All the gate models are space efficient security barriers with a compact design, yet offer sufficient space to integrate any access control system. They can be mounted with card readers, biometric readers, remote control and push button units via simple dry contact.

The Alaris-Full Height model is a bidirectional gate with a passage width of 50-55 cm. Side and center units are produced to create as many passage lanes as required. Thanks to the built in sensor technology, the gate provides both safe and secure passage. Status indicator LED lights are located on both directions of the gate, in green and red colors to show allowed passage directions.

In case of an emergency or power failure, the gate provides a fail-safe working solution by allowing free passage on both directions.

## TURNSTILE

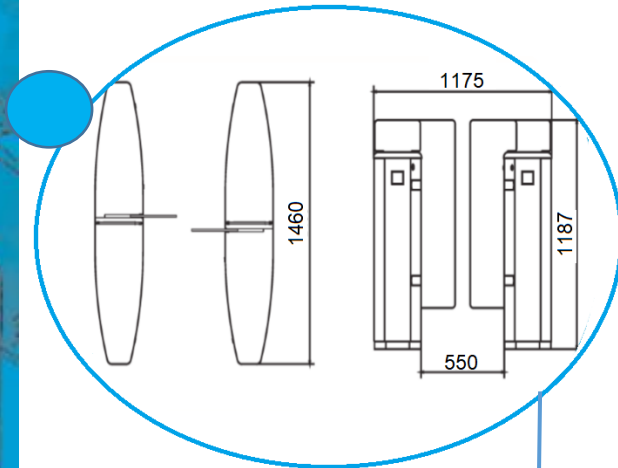

### Specifications

- Case Dimensions (WxLxH):316x1460x1187 mm
- Clear Walkway-adjustable: 500-550mm
- Drive: Motorized
- Top Cover: Special pvc covered wood
- Front Cover: 304 Grade SS
- Wing Housing:304 Grade SS
- Indicators: LED Bars
- Wings: 10 mm glass
- Side Covers: 304 Grade SS
- Weight: 100 kg
- Power Supply: 115/230W AC50/60Hz
- Operation Voltage:24VDC+-20%
- Passage Per Minute: 20-30
- Opening/Closing Period: 0,30-0,50



**B.E.C.**  
PERIMETER SECURITY

### CONTACT

T: 02089654178 E: [info@becuk.london](mailto:info@becuk.london)

Address: 2, River Brent Business Park, Trummers Way, Ealing  
London W7 2QA